



## K822 CAPE CORAL SR. - LED

The K822 Cape Coral Sr. is a modern take on the traditional bell shape with a sloping shroud, engineered to increase roadway performance while providing superior spacing. Suitable for off roadway applications as well, this time-less design can be used in both contemporary and historical settings.



# King Luminaire

## PRODUCT SPECIFICATIONS

### LED ENGINE

Light engine shall include an array of 60 or 84 solid state Cree X-Series high power LEDs (light emitting diodes). The emitters shall be mounted to a metal core circuit board using SMT technology. The LEDs and circuit boards shall then be mounted to a high performance heat sink which is vented to the outside ambient air to provide dynamic airflow for cooling the system.

### OPTICS

External light control shall consist of high precision refractive lenses mounted above the LED emitter arrays in such a way to achieve optimum uplight control. The lenses shall also control horizontal light distribution so that Type II, III, IV or V IESNA distribution patterns are achieved.

### LENS

The K822 Cape Coral Sr. pendant is available with or without a lens. Lens options include; clear sag glass lens; clear shallow glass lens; rippled acrylic deep dish lens or rippled glass deep dish lens. The sag and shallow glass lens shall be made of #9000 clear borosilicate glass (fully annealed). It shall maintain a minimum thickness of 0.3". The rippled acrylic deep dish globe shall be moulded of acrylic Acrylite Plus Acrylic Polymer, or equivalent, having a minimum thickness of 0.09". The rippled glass deep dish lens shall be made of clear borosilicate glass (fully annealed) with a rippled pattern. It shall maintain a minimum thickness of 0.25". The lens is secured by means of a cast aluminum holding ring. Additionally, a continuous circular gasket rated for 270°F will assist in sealing the lens and provide an IP66 ingress rating.

### LUMINAIRE CONSTRUCTION

The luminaire shall consist of an aluminum alloy housing that acts as the enclosure for the engine and is of adequate thickness to give structural rigidity. The engine must be affixed to the inside of the housing with stainless steel screws.

The bottom decorative portion of the K822 Cape Coral Sr. fixture is comprised of a one-piece spun aluminum alloy with a minimum thickness of 0.09". The spinning is permanently affixed to the cast housing with the use of stainless steel hardware.

### PLUMBIZER

The K822 Cape Coral Sr. comes with multiple mounting options including the KPL10, KPL11, KPL20, KPL21, KPL30, KPL31 and KPL40. Please contact King Luminaire for more details and specifications.

### DRIVER

The LED universal dimmable driver will be class 2 and capable of 120 - 277V or 347 - 480V input voltage, greater than 0.9 power factor, less than 20% total harmonic distortion. The case temperature of the driver can range from -40°C to 70°C. Each LED system comes with a standard surge protection designed to withstand up to 20kV/10kA of transient line surge as per IEEE C62.41.2 C High. An in-line ferrite choke is utilized to provide protection against EFT's. The driver assembly will be mounted on a heavy duty fabricated aluminum bracket to allow complete tool-less maintenance. Dimming capable using 1-10vdc (10% to 100%), 10v PWM, or resistance.

### PHOTOMETRICS

Fixtures are tested to IESNA LM79 specifications. These reports are available upon request.

### CHROMATICITY

High output LEDs come standard at 3000K & 4000K (+/- 300K) with a minimum nominal 70 CRI. Additional CCT emitters are available upon request.

### LUMEN MAINTENANCE

Reported (TM21) and Calculated (L70) reports are available upon request with a minimum calculated value of 100,000 hrs.

### WIRING

All internal wiring and connections shall be completed so that

it will be necessary only to attach the incoming supply connectors to Mate-N-Lok connectors or to a terminal block. Mate-N-Lok shall be certified for 600V operation. Internal wire connectors shall be crimp connector only and rated at 1000V and 150°C. All wiring to be CSA certified and/or UL listed, type SFF-2, SEWF-2, or SEW-2 No. 14 gauge, 150°C, 600V, and color coded for the required voltage.

### THERMALS

Fixtures tested to DOE sanctioned standards to determine the maximum in-situ solder-point or junction-point temperatures of the LED emitters. This report is available upon request.

### FINISH

Housing is finished with a 13 step KingCoat™ SuperDurable polyester TGIC powder coat. Standard colors include strobe white, brown metal, marina blue, gate gray, Chicago bronze, standard gold, standard black, federal green and rain forest. Please see our website for a complete list of colors. RAL and custom color matches are available.

### MISCELLANEOUS

All exterior hardware and fasteners, wholly or partly exposed, shall be stainless steel alloy. All internal fasteners are stainless steel or zinc coated steel. All remaining internal hardware is stainless steel, aluminum alloy, or zinc coated steel.

### WARRANTY

The K822 Cape Coral Sr. LED luminaire comes with a 7 year limited warranty.

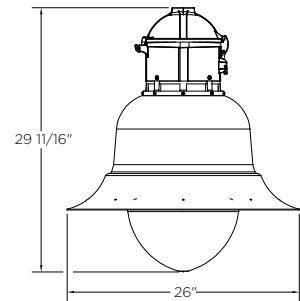

### CERTIFICATION:

CSA US Listed  
Suitable for wet locations  
ISO 9001  
IP66  
ARRA Compliant  
LM79 / LM80 Compliant

### DRIVER INFO:

>0.9 Power Factor  
<20% Total Harmonic Distortion  
120 - 277V & 347 - 480V  
-40°C Min. Case Temperature  
70°C Max. Case Temperature  
Surge Protection: ANSI C136.2  
extreme level 20kV/10kA  
Dimming Capable: 1-10vdc

### EPA:

Flat Lens:	1.61 sq. ft.
Sag Lens:	1.71 sq. ft.
Shallow Lens:	2.03 sq. ft.
Deep Dish Acrylic:	2.48 sq. ft.
Deep Dish Glass:	2.48 sq. ft.

### FIXTURE WEIGHT:

Flat Lens:	32 lbs
Sag Lens:	37 lbs
Shallow Lens:	40 lbs
Deep Dish Acrylic:	40 lbs
Deep Dish Glass:	45 lbs



Contact King Luminaire for product specifications that are exempt from CSA Certification. 08-11-2021

## Lens Options

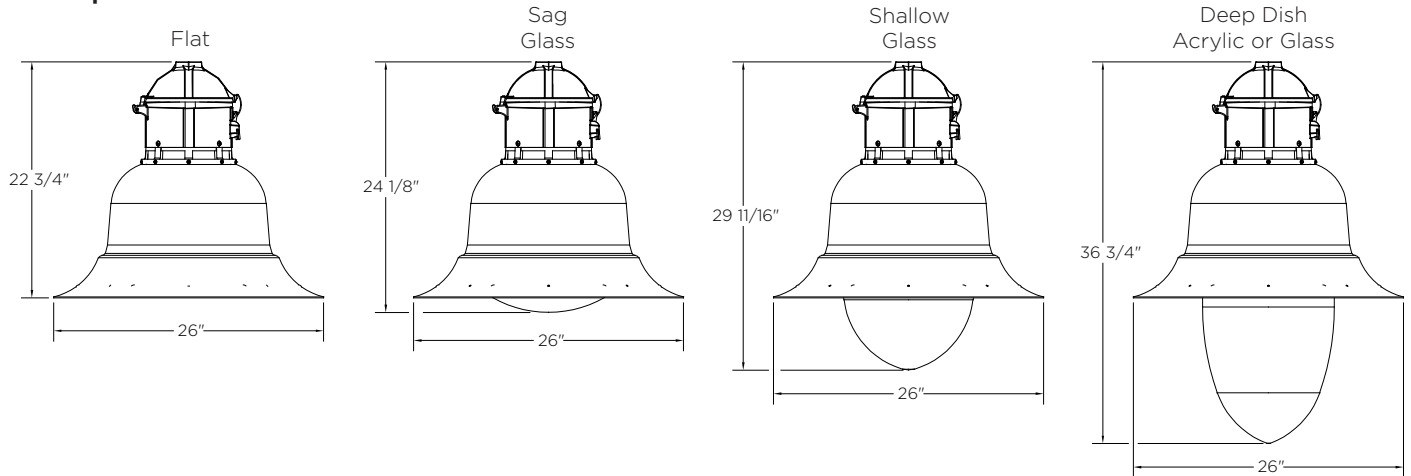

## Plumbizer/Mounting Options

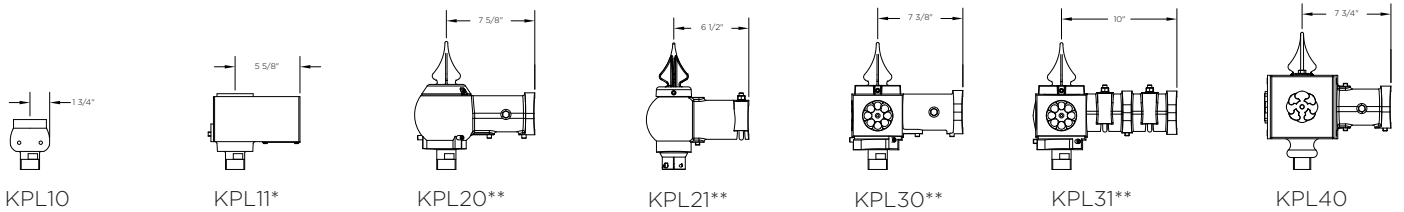

\*Available with PR7  
 \*\*Available with PR7 or finial

## HOW TO ORDER

